

J704 Alarming Showcase / Technical Specifications

SPECIFICATIONS

J704 Base (DUW100-W):

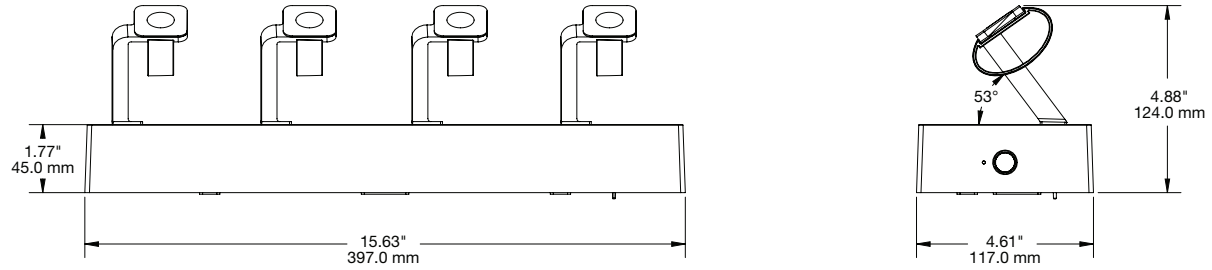

J704 Lid / Cover - Clear (DUW400):

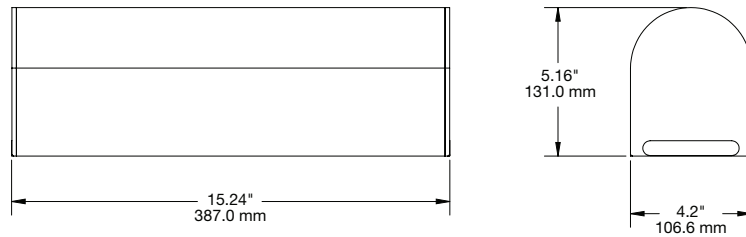

SPECIFICATIONS

J704 Watch Stem and Band Form (DUW401):

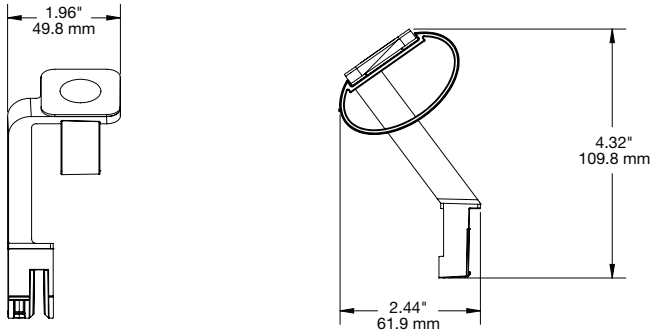

W1000 / J704 Clear Watch Band Form - 4 Pack (DUW403):



SPECIFICATIONS

J704 / W1000 - Apple Trim (DVW404):

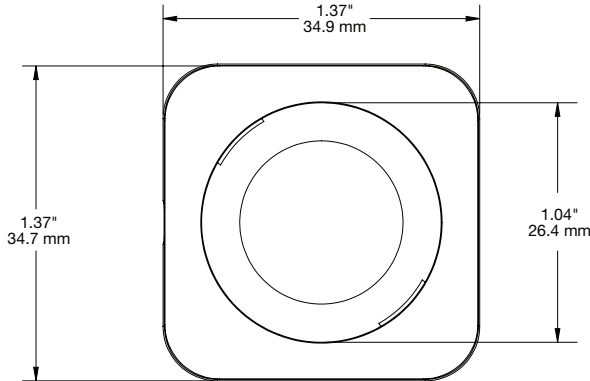

J704 / W1000 - Fitness Band Cradle (DVW405):

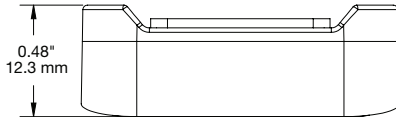
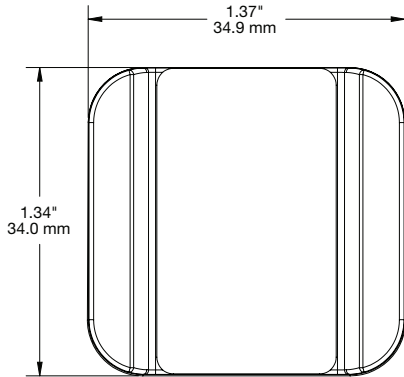

SPECIFICATIONS

J704 / W1000 - Pebble Trim (DVW406):

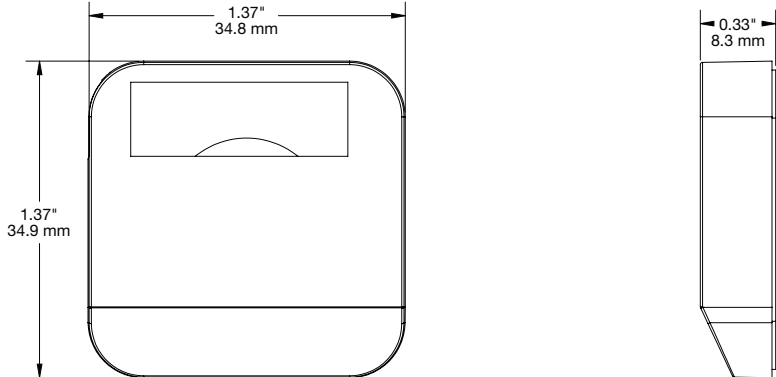

J704 / W1000 Fossil Watch Trim (DVW412):

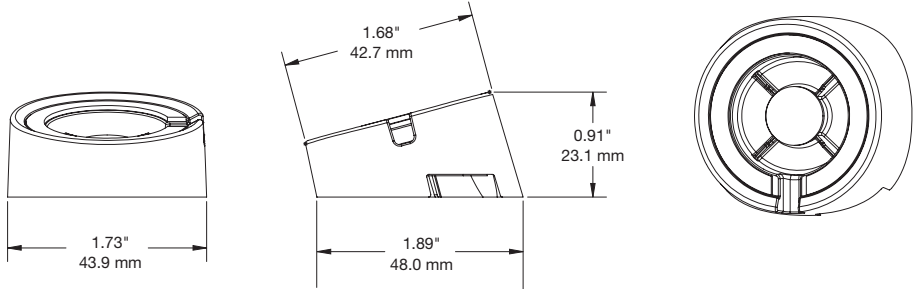

J704 Alarming Showcase / Technical Specifications

PRODUCT ORDERING

ORDER CODE	DESCRIPTION	NOTES	CARTON QTY.
DUW100-W	J704 Base - White	<ul style="list-style-type: none"> › Includes base, metal plate, and four watch stems, band forms, velcro bands, PSAs, and silicone pads › Requires DUW400 lid › Replacement adhesive: ADH2040 	6
DUW400	J704 Lid / Cover - Clear		3
DUW401	J704 Replacement Stem & Band Form - Single Pack	› Replacement adhesive: ADH2111	32
DUW402	Replacement Velcro Bands - 4 Pack		32
DUW403	W1000 / J704 Clear Watch Band Form - 4 Pack		32
DUW405	J704 Metal Plate - Replacement Kit		32
DVW404	W1000 / J704 Apple Trim	› Replacement adhesive: ADH2113	96
DVW405	W1000 / J704 Fitness Band Cradle	<ul style="list-style-type: none"> › It is recommended that fitness band displays use DVW405 for proper band placement › Replacement adhesive: ADH2113 	96
DVW406	W1000 / J704 Pebble Trim	› Replacement adhesive: ADH2113	96
DVW412	W1000 / J704 Fossil Watch Trim	› Replacement adhesive: ADH2113	32
ADH2040	Base Replacement Adhesive - 15 Pack	› For DUW100	20
ADH2111	W1000 / J704 Stem Replacement Adhesive & Silicone Pads - 8 Pack	› For DUW100 stems and DUW401	20
ADH2113	W1000 / J704 Trim/Cradle Replacement Adhesive - 8 Pack	› For trims and cradles	20
EC9154	Power Supply 5.3V	› Requires C7 power cable	32
YC9	C7 AC Power Cable - US	› For EC9154	100
YC10	C7 AC Power Cable - UK	› For EC9154	100
YC11	C7 AC Power Cable - EU	› For EC9154	100
YC12	C7 AC Power Cable - AU	› For EC9154	100

invue.com

©2018 InVue Security Products. No endorsement of InVue products has been made by any of the manufacturers of the products shown. Product is sold pursuant to InVue's warranty which can be found at www.invue.com/warranty.

THE AMERICAS 704.752.6513 • 888.55.INVUE
EUROPE, MIDDLE EAST & AFRICA +31.23.8900150
ASIA PACIFIC +852.3127.6811



rev. 07/02/18

