

## SPECIFICATIONS

Series 3000 Base (DWD100-W):

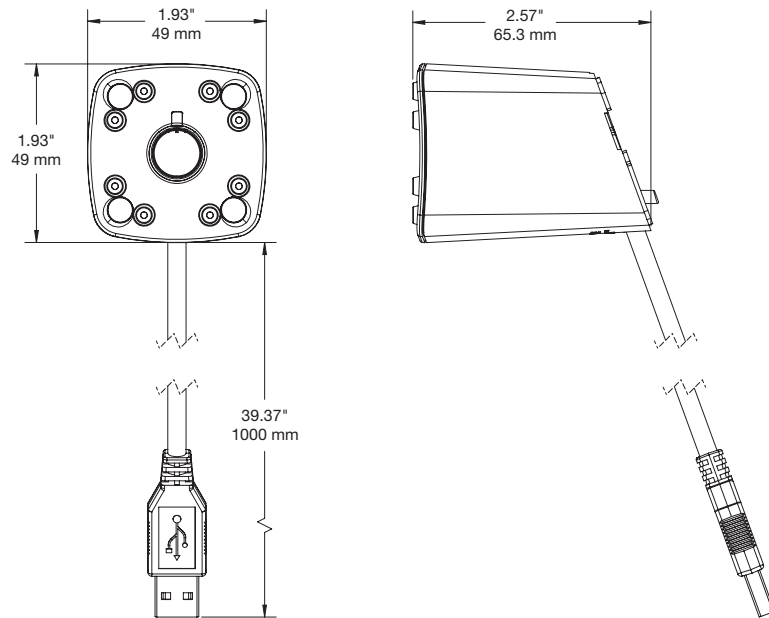

Series 3000 Handheld Sensor Micro USB (DWH200-W):

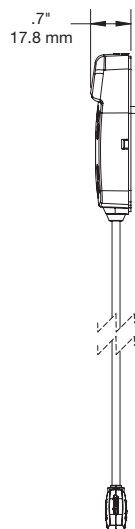
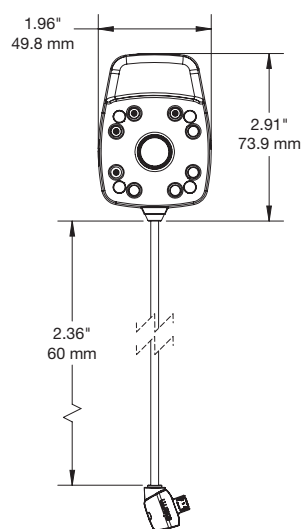

**SPECIFICATIONS**

Series 3000 Tablet Sensor Micro USB (DWT200-W):

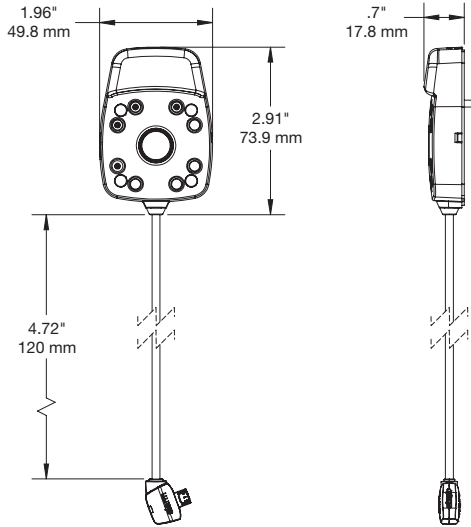

Series 3000 Handheld Sensor Apple Lightning (DWH203-W):

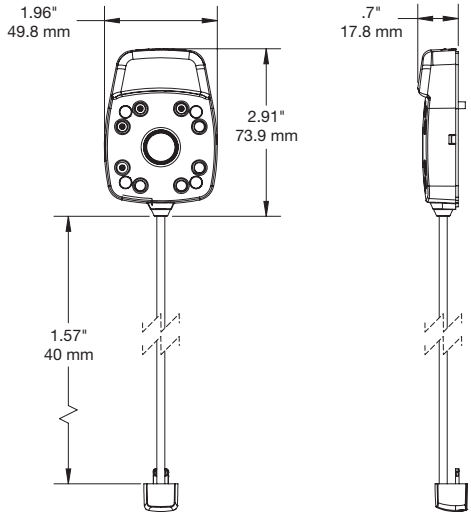

**SPECIFICATIONS**

Series 3000 Tablet Sensor Apple Lightning (DWT203-W):

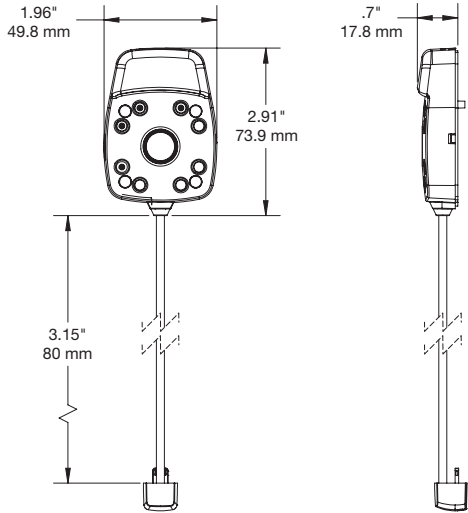

### PRODUCT ORDERING

ORDER CODE	DESCRIPTION	CARTON QTY.
DWD100-W	Series 3000 Base - Gold LED	32
DWH200-W	Series 3000 Handheld Sensor Micro USB - Gold LED	32
DWT200-W	Series 3000 Tablet Sensor Micro USB - Gold LED	32
DWH203-W	Series 3000 Handheld Sensor Apple Lightning - Gold LED	32
DWT203-W	Series 3000 Tablet Sensor Apple Lightning - Gold LED	32
ADH2068	Series 3000 Stand Adhesive, 8 Pack	20
ADH2069	Series 3000 Sensor Adhesive, 8 Pack	20
PS515-US	5V Power Supply USB-A - US	32
PS515-UK	5V Power Supply USB-A - UK	
PS515-EU	5V Power Supply USB-A - EU	
PS515-AUS	5V Power Supply USB-A - AUS	

[invue.com](http://invue.com)

©2018 InVue Security Products. No endorsement of InVue products has been made by any of the manufacturers of the products shown. Product is sold pursuant to InVue's warranty which can be found at [www.invue.com/warranty](http://www.invue.com/warranty).

**THE AMERICAS** 704.752.6513 • 888.55.INVUE  
**EUROPE, MIDDLE EAST & AFRICA** +31.23.8900150  
**ASIA PACIFIC** +852.3127.6811